

# Installation Sheet (Wiegand Interface) (Part No. 004-98-A) Sentinel-Prox MR-1824 and MR-1824-MC Readers



## Reader Description

The Sentinel-Prox MR-1824 Reader is a medium-range radio-frequency proximity reader for Gate Control and Access Control Systems. The Reader consists of a transmit/receive antenna and reader electronics in a polycarbonate housing. The reader electronics are potted with epoxy resin to protect against the environment. **MR-1824** may be mounted on any non-metallic surface. **MR-1824-MC** is a metal-compensated version of this reader for mounting on or near a metal surface. See page 4 for Procedure on installing MR-1824-MC.

## Parts List

(a) Installation sheet, P/N 004-98-A (Revision ZB).....	1	(d) Plastic anchor, P/N 004-30-B .....	4
(b) Sentinel-Prox MR-1824 or MR-1824-MC Reader, P/N 004-20-A .....	1	(e) Screw-hole plug, P/N 004-27-A (1 spare) .....	5
(c) #6-20 x 1.375" self-tapping screw, P/N 004-30-A ..	4	(f) Cable slot plug, P/N 004-27-B .....	2
		(g) Ferrite clamp, P/N FC.....	1

## Installation Procedure

1. Position the reader (item b in the Parts List) at the desired location. Observe ADA height requirements. Drill four holes for the screws or anchors, and drill one clearance hole for the cable (see Figure 1). The installer determines the size of mounting holes and cable clearance hole.
2. Clip off the white 10-pin connector from the end of the reader's cable. Keep the wires as long as possible.
3. Connect the reader's Data-0, Data-1, power and ground wires as shown in Figure 2. **Do not connect** the *orange, yellow, blue, violet* and *brown* wires to anything. **Tape or cap** all unused wires singly.
4. Use a **linear regulated** DC power supply, between 5 volts DC (current rating at least **1.0** ampere) and 12.0 volts DC (at least **1.5** amperes). For maximum read range, do not exceed **12.0** volts. **Do not power** the MR-1824 from the panel's internal power supply -- use an external DC power supply. **Tie the ground side** of all DC circuits together – including the reader (black wire), the panel's reader input port (ground terminal), the external power supply (negative terminal), and the door or gate relay (common).
5. Install the ferrite clamp (item g in the Parts List) on the +DC power, DC ground, and drain wires. See instructions on page 3.
6. To install the reader's cable through the wall directly behind the reader, insert both cable slot plugs (item f in the Parts List) in the sides of the reader's plastic cover. To run the cable exiting from the side of the reader, press-fit the cable into the curved channel and guide the cable out of the desired side of the reader. Then insert the cable slot plug in the other side of the plastic cover.
7. Install the reader on the mounting surface, using screws (item c) and anchors (item d) as necessary.
8. Apply power to the reader. The LED is steady-green. The beeper sounds a *Short-Short-Short* <pause> *Short* beep sequence. Then the LED changes to flashing-red indicating Standby mode. The reader is now initialized and can read cards. **Note:** All credentials (cards, tags and wafers) must be AWID's products.
9. When installation is complete and the reader has been tested, insert screw-hole plugs (item e in the Parts List) into the screw clearance holes to conceal the screw heads. Note: Screw-hole plugs are for one-time use. After they are seated, they cannot be removed without damaging the plugs.

## Product Specifications

### Material of the Mounting Surface

- MR-1824.....*Non-metallic* material only (Keep the reader 3 inches *or more* from all metal.)
- MR-1824-MC.....Any material including metal (The best read range is about 2/3 of MR-1824 read range.)

### Cable to Controller

- 4 conductors (not twisted pairs), stranded, 18 AWG, color-coded insulation, overall 100% shielded  
Note: Wire may be 22 gauge for data lines **if** DC power is run in a separate 18 gauge cable.

- Length for Wiegand Interface..... Up to 500 feet

(continued)

Read Range with AWID's CS card (Typical) **MR-1824**

**MR-1824-MC**

- At 5 VDC..... About 6 inches (15 cm) .....About 4 inches (10 cm)
- At 12 VDC..... 9 to 12 inches (23 to 30 cm) .....Up to 8 inches (20 cm)

**Characteristics**

- Indoor and Outdoor ..... Rated for outdoor installations
- Operating Temperature..... -35° C to 65° C (-31° F to 150° F)
- Operating Humidity..... 0 to 95% non-condensing

**Operating Parameters**

- Excitation Frequency..... 125 kHz
- Wiegand Output..... 26 bits to 50 bits (as programmed in the cards or tags)

Certifications..... FCC Part 15; Industry Canada; UL listed

**Notes**

- Remove power before wiring changes. Read attached memo "MR-1824 - Achieving Maximum Read Range".
- MR-1824 and MR-1824-MC readers have both Wiegand-protocol and RS-232 serial interfaces. For information on RS-232, contact AWID's Technical Support.
- For additional information, please visit AWID's Web site [www.awid.com](http://www.awid.com). For technical support questions visit [www.awid.com/support](http://www.awid.com/support) or call **1-800-369-5533** (in the U.S.) or **+1-408-825-1100** from 8:00 a.m. to 5:00 p.m. PST.
- FCC Compliance: This equipment has been tested and found to be in compliance with the limits for FCC part 15, Class A digital device. These limits are designed to provide reasonable protection against harmful interference when the equipment is operated in a commercial environment. This equipment generates, uses and can radiate radio frequency energy and, if not installed and used in accordance with instruction manual, may cause harmful interference with radio communications. Operation of this equipment in a residential area is likely to cause harmful interference in which case the user will be required to correct the interference at his own expense.  
The users are prohibited from making any change or modification to this product. Any modification to this product shall void the user's authority to operate under FCC Part 15 Subpart A Section 15.21 regulations. This device complies with Part 15 of the FCC Rules.  
Operation is subject to the following two conditions: (1) This device may not cause harmful interference, and (2) this device must accept any interference received, including interference that may cause undesired operation.
- Industry Canada Compliance: Operation is subject to the following two conditions: (1) This device may not cause harmful interference, and (2) this device must accept any interference, including interference that may cause undesired operation of the device.

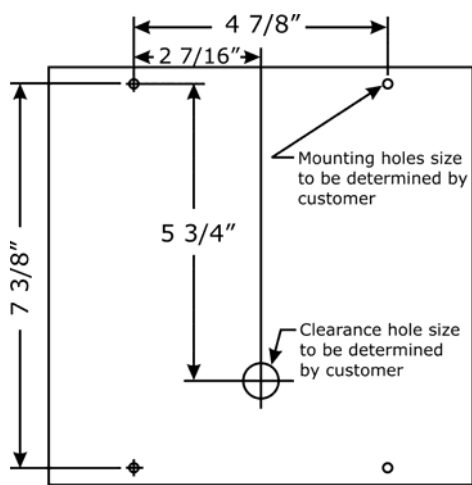

FIGURE 1. Holes Location

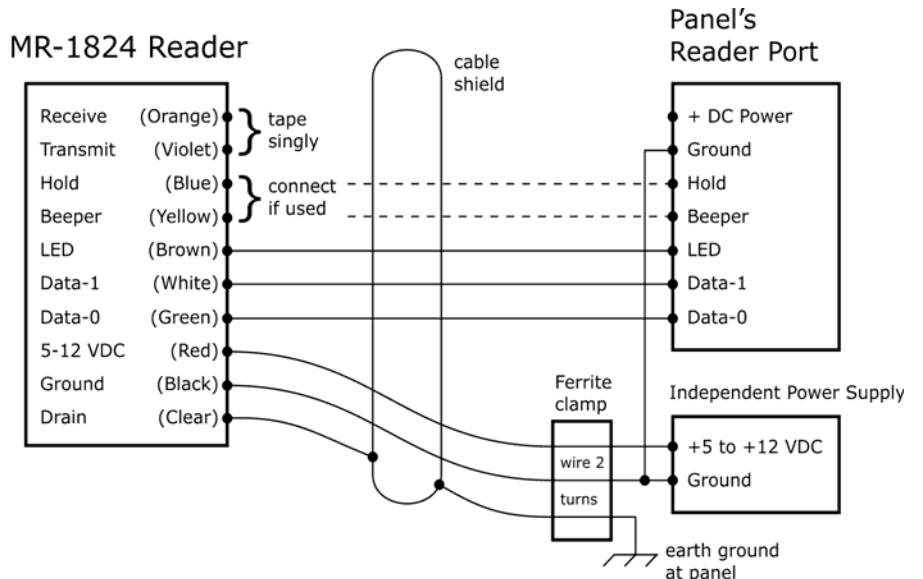

FIGURE 2. Wiring Diagram (Wiegand)

## Instructions

### INSTALLING FERRITE CLAMP ON POWER SUPPLY CABLE

*To meet the requirements of the FCC, AWID supplies a “ferrite clamp” for installation on the power supply wiring. The clamp can be installed by hand, easily and quickly, at the site, without removing the reader or its wiring. This procedure may be used on a power supply that was installed earlier, or on one being newly installed.*

*Three wires must pass through the ferrite’s channel when it is snapped closed – (a) the positive DC, (b) the DC ground, and (c) the drain wire from the reader and the cable’s shield to earth-ground.*

1. Locate the low-voltage DC power supply and the wires that connect it to the MR-1824 reader or the MR-1824-MC reader.
2. Arrange for enough excess wire length so that the wires can loop through the ferrite clamp with two turns of the wires inside the channel of the clamp.
3. Hold the open clamp (Figure 3) at a place where the three wires are accessible.
4. Loop the wires twice around the channel in the ferrite. Pull the wire loop *tightly* around the ferrite clamp.
5. Press the ferrite clamp around the wires until the latch at one end of the clamp snaps over the ears on the other end of the clamp. (See Figure 4.)



FIGURE 3. Ferrite clamp (open)

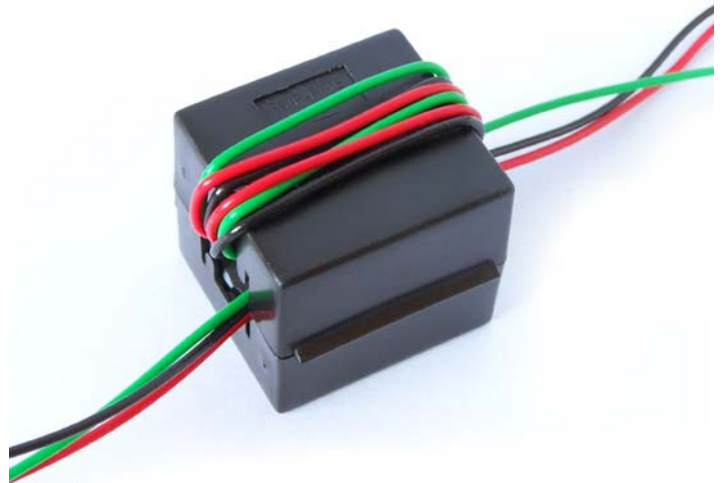

FIGURE 4. Ferrite clamp locked on 3 wires

**Note:** If it is necessary to remove the ferrite clamp from the wires, insert a fingernail under the latch and lift it off the ears. The clamp will then swing open.

## Instructions

### Installing MR-1824-MC

#### Notes for MR-1824-MC

- Use **MR-1824-MC**, the metal-compensated version of the MR-1824 reader, when mounting the reader on a metal surface. Nearby metal will cause the magnetic field around the MR-1824 reader to become smaller. The MR-1824-MC reader will sustain the field, but at a reduced strength.
- Follow the steps below in place of steps 1 to 4 on page 1 of the Installation Sheet for the MR-1824.

#### Installation Procedure

1. To mount the **MR-1824-MC** reader on the metal surface:
  - a. Remove the 4 screws through the front of the reader's plastic housing. This reveals the reader body with 4 mounting holes, aligned to the center holes of the 4 ferrite tiles.
  - b. Use the ferrite tiles as templates for mounting holes on the metal surface. These holes are at the center of each 4" X 4" tile. The center of the hole is 2" from each edge.
  - c. If necessary, enlarge the hole in the ferrite tiles slightly by drilling or reaming.
  - d. Screw the reader's plastic base and the ferrite tiles to the wall by inserting the 4 screws (item c in the Parts List on page 1) first through the inside of the plastic base, then through the holes in the ferrite tiles, then into the mounting holes in the wall.
  - e. Re-attach the reader's plastic cover using the screws that were removed in step 1.a.
2. Clip off the white 10-pin connector from the end of the reader's cable. Keep the wires as long as possible.
3. Connect the reader's cable to the controller panel as shown in Figure 2 on page 2.
  - a. Connect the **yellow** wire only if used for Beeper control by the panel
  - b. Connect the **blue** wire only if used for Hold control by the panel.
  - c. **Do not connect** the orange and violet wires to anything.
  - d. **Tape or cap all unused wires singly.**
4. Use a **linear regulated** DC power supply, between 5 volts (170 mA peak) and 12.0 volts **maximum** (350 mA peak).
  - a. **Do not power** the MR-1824-MC from the panel's internal power supply – use an external DC power supply.
  - b. For guaranteed performance, a power module P/N PS12-1A is available from AWID.
  - c. **Tie the ground side of all DC circuits together** – including the reader, the panel's reader input port, the external DC power supply, and the door or gate release.

Continue with "Installation Procedure" at step 5 on page 1.