

# Installation Sheet (Wiegand Interface)

## Sentinel-Prox SP-6820 Reader



### Reader Description

The Sentinel-Prox SP-6820 Reader is a radio-frequency proximity reader for Access Control Systems. The Reader consists of a transmit/receive antenna and reader electronics in a polycarbonate housing. The reader electronics are potted with epoxy resin to protect against the environment. The SP-6820 Reader may be mounted like a cover plate on a single-gang electrical utility box, or on any surface (wall, cabinet, etc.).

### Parts List

(a)	Installation Sheet	Qty=1
(b)	Sentinel-Prox SP-6820 Reader, P/N 003-20-A	Qty=1
(c)	#6-32 x 1" machine screw, P/N 0616MPP	Qty=2

### Installation Procedure

1. Install a single-gang electrical utility box, or drill two no. 27 (0.144-inch) clearance holes for the reader's screws and one hole for the cable, at the desired location. Observe ADA height requirements.
2. Snap open the reader's top cover by inserting a wide screwdriver blade into the slot at the bottom edge of the cover, then twisting the blade gently (see Figure 1).
3. Clip off the white 10-pin in-line connector from the end of the reader's cable. Keep the wires as long as possible.
4. Connect the reader's cable to the controller panel as shown in Figure 2. Connect the **blue** wire to the panel's *Green LED* terminal, and the **brown** wire to the *Red LED* terminal. Connect the **yellow** wire only if used for Beeper control by the panel. **Do not connect** the *orange* and *violet* wires. **Tape or cap** all unused wires singly.
5. Use a linear regulated DC power supply, between 5 volts (rated at least 50 mA) and 12 volts (rated at least 80 mA). Connect the reader's **black** and **red** wires to this power supply. This may be the panel's DC supply.
6. Install the reader on the electrical utility box or other surface. Fasten the reader to the utility box with the supplied screws (item c in the Parts List).
7. Hold the reader's top cover over the base reader, and snap the cover closed securely.
8. Power up the reader. The LED is steady amber. (The beeper does not sound.)
9. Present any AWID proximity credential (card, keytag, or wafer) briefly to the reader. The beeper sounds a *Long-Short-Long* sequence. The reader is now initialized and can read cards. In Standby mode, the LED colors are controlled totally by the host system (not by the reader). Credentials must be AWID's products.

### Product Specifications

#### Cable to Controller

- 6 or 7 conductors (not twisted pairs), stranded, 22 gauge, color-coded insulation, overall 100% shielded  
Note: The number of conductors depends upon use of the optional beeper control. See Figure 2.
- Length for Wiegand interface..... Up to 500 feet

#### Read Range with AWID Card (Metal-Compensated Reader)

- At 5 VDC ..... Typically 6 inches (15 cm)
- At 12 VDC..... Typically 8 inches (20 cm)

#### Characteristics

- Indoor and Outdoor ..... Rated for outdoor installations
- Operating Temperature Range..... -35° C to 65° C (-31° F to 150° F)
- Operating Humidity..... 0 to 95% non-condensing

#### Operating Parameters

- Excitation Frequency ..... 125 kHz
- Wiegand Output ..... 26 bits to 50 bits (as programmed in the cards or tags)
- Width of Wiegand data pulses..... 100 microseconds

Certifications ..... FCC Part 15; Industry Canada; UL listed; CE

**Notes**

1. When wiring the reader, connect the black wire (ground) first, and the red wire (power) last.
2. When the yellow wire is not used, the beeper remains active and under the reader's internal control.
3. The LED and Beeper lines are logic levels. *Never* apply power to them. They may be pulled to a low level (0 to 1.2 VDC) to enable their function, and left floating at a high level (3.6 to 5.0 VDC) when not used.
4. SP-6820 readers have both Wiegand-protocol and RS-232 serial interfaces. For information on RS-232, contact AWID's Technical Support.
5. For additional information, please visit AWID's Web site ([www.awid.com](http://www.awid.com)). For technical support questions visit [www.awid.com/support](http://www.awid.com/support) or **1-800-369-5533** (in the U.S.) or **+1-408-825-1100** from 8:00 a.m. to 5:00 p.m. Pacific Time.
6. FCC Compliance: This equipment has been tested and found to be in compliance with the limits for FCC part 15, Class A digital device. These limits are designed to provide reasonable protection against harmful interference when the equipment is operated in a commercial environment. This equipment generates, uses and can radiate radio frequency energy and, if not installed and used in accordance with instruction manual, may cause harmful interference with radio communications. Operation of this equipment in a residential area is likely to cause harmful interference in which case the user will be required to correct the interference at his own expense.

The users are prohibited from making any change or modification to this product. Any modification to this product shall void the user's authority to operate under FCC Part 15 Subpart A Section 15.21 regulations.

This device complies with Part 15 of the FCC Rules. Operation is subject to the following two conditions: (1) This device may not cause harmful interference, and (2) this device must accept any interference received, including interference that may cause undesired operation.

7. Industry Canada Compliance: Operation is subject to the following two conditions: (1) This device may not cause harmful interference, and (2) this device must accept any interference, including interference that may cause undesired operation of the device.

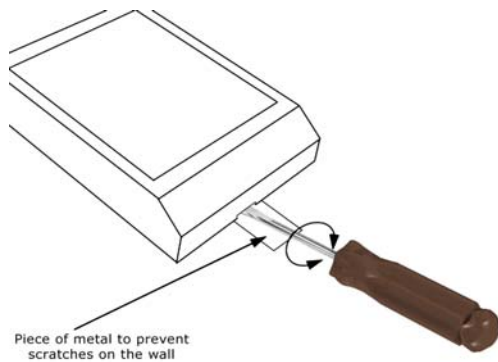

FIGURE 1: Snapping Open The Cover

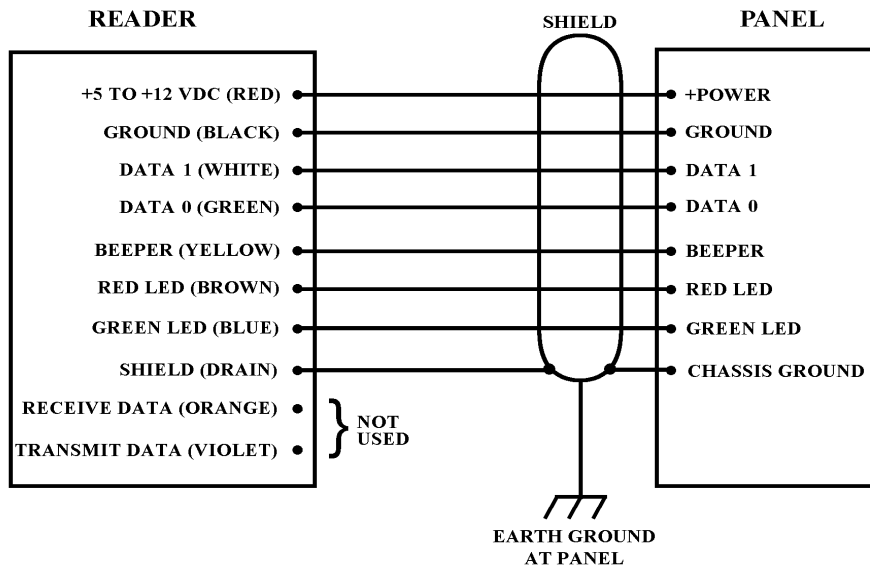

FIGURE 2: Wiring Diagram (Wiegand)