

Installation Sheet (Wiegand Interface)

Sentinel-Prox SR-2400 Reader



Reader Description

The Sentinel-Prox SR-2400 Reader is a radio-frequency proximity reader for Access Control Systems. The Reader consists of a transmit/receive antenna and reader electronics, in a polycarbonate housing. The reader electronics and antenna are potted with epoxy resin to protect against the environment. The Reader may be mounted on a metal doorframe, a window mullion, or any surface (wall, cabinet, etc.).

Parts List

(a)	Installation sheet	Qty=1
(b)	Sentinel-Prox SR-2400 Reader	Qty=1
(c)	#6-32 x 1" thread-cutting screw, Type 23	Qty=2
(d)	Screw-hole plug	Qty=3 (1 spare)

Installation Procedure

1. Position the reader (item b in the Parts List) at the desired location. Observe ADA height requirements. Drill two 7/64 (0.109)-inch holes for the reader screws, and one clearance hole for the cable (see Fig. 1).
2. Clip off the white 10-pin in-line connector from the end of the reader's cable. Keep the wires as long as possible.
3. Connect the reader's ground, Data-0, Data-1, Reader Control, and power (see Figure 2). Connect the *yellow* wire only if used for Beeper control by the panel. **Do not connect** the *orange, blue, and violet* wires to anything. **Tape or cap** the unused wires separately.
4. Use a linear regulated DC power source, 12 volts output, with current capacity at least 70 milliamperes. The power source may be the Ground and Power terminals on the controller's reader port, or the vehicle's DC power circuit.
5. Install the reader in the vehicle as instructed. Fasten the reader to the surface using supplied screws (item c in the Parts List) or other fasteners, adhesive or sealant.
6. Apply power to the reader. The LED is steady-green. The beeper sounds the following sequence: *Short-Short-Short* <pause> *Long-Short*. Then the LED changes to flashing-red indicating Standby mode (if the reader is enabled by the panel). The reader is now initialized and can read cards. (See Note 3.)
Note: All credentials must be AWID's products. Credentials from other companies will not read.
7. When installation is complete and the reader has been tested, insert screw-hole plugs (item d in the Parts List) into the screw clearance holes to conceal the screw heads. Note: Screw-hole plugs are for one-time use. After they are seated, they cannot be removed without damaging the plugs.

Product Specifications

Cable to Controller

- 5 or 6 conductors (not twisted-pair), stranded, 22 gauge, color-coded insulation, overall 100% shielded
Note: The number of conductors depends upon use of the optional Beeper control. See Figure 2.
- Length for Wiegand interface..... Up to 500 feet

Read Range with AWID Card (Metal-Compensated Reader)

- At 12 volts DC..... Typically 5.5 inches (14 cm)

Characteristics

- Indoor and Outdoor Rated for outdoor installations
- Operating Temperature Range -35° C to 65° C (-31° F to 150° F)
- Operating Humidity..... 0 to 95% non-condensing

Operating Parameters

- Excitation Frequency..... 125 kHz
- Wiegand Output26 bits to 50 bits (as programmed in the cards or tags)

CertificationsFCC Part 15; Industry Canada; UL listed; CE

Notes

1. Connect the reader’s black wire (ground) first, and the red wire (power) last. Remove power before any wiring change.
2. The brown and yellow wires are logic-level control lines. *Never* apply power to them. They may be pulled to a low level (0 to 1.2 VDC) to enable their functions, and left floating at a high level (3.6 to 5.0 VDC) when they are not used.
3. When the reader is disabled, the LED is steady-red. When the reader is enabled, the LED is flashing-red. When a valid AWID card or keytag is presented to the reader, the LED is amber for less than 1 second, then it reverts to flashing-red.
4. SR-2400 readers have Wiegand-protocol electrical interface only. (There is no RS-232 interface.)
5. For additional information, please visit AWID’s Web site www.awid.com . For technical support questions visit www.awid.com/support or call **1-800-369-5533** (in the U.S.) or **+1-408-825-1100** from 8:00 a.m. to 5:00 p.m. PST.
6. FCC Compliance: This equipment has been tested and found to be in compliance with the limits for FCC part 15, Class A digital device. These limits are designed to provide reasonable protection against harmful interference when the equipment is operated in a commercial environment. This equipment generates, uses and can radiate radio frequency energy and, if not installed and used in accordance with instruction manual, may cause harmful interference with radio communications. Operation of this equipment in a residential area is likely to cause harmful interference in which case the user will be required to correct the interference at his own expense.

The users are prohibited from making any change or modification to this product. Any modification to this product shall void the user’s authority to operate under FCC Part 15 Subpart A Section 15.21 regulations.

This device complies with Part 15 of the FCC Rules. Operation is subject to the following two conditions: (1) This device may not cause harmful interference, and (2) this device must accept any interference received, including interference that may cause undesired operation.

7. Industry Canada Compliance: Operation is subject to the following two conditions: (1) This device may not cause harmful interference, and (2) this device must accept any interference, including interference that may cause undesired operation of the device.

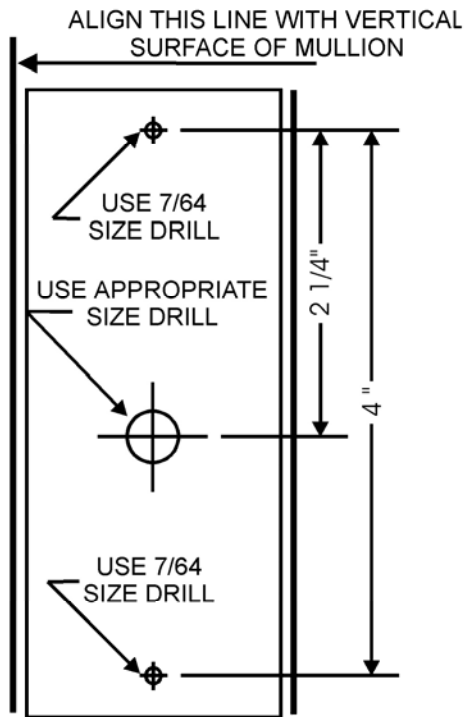

FIGURE 1. Holes Location

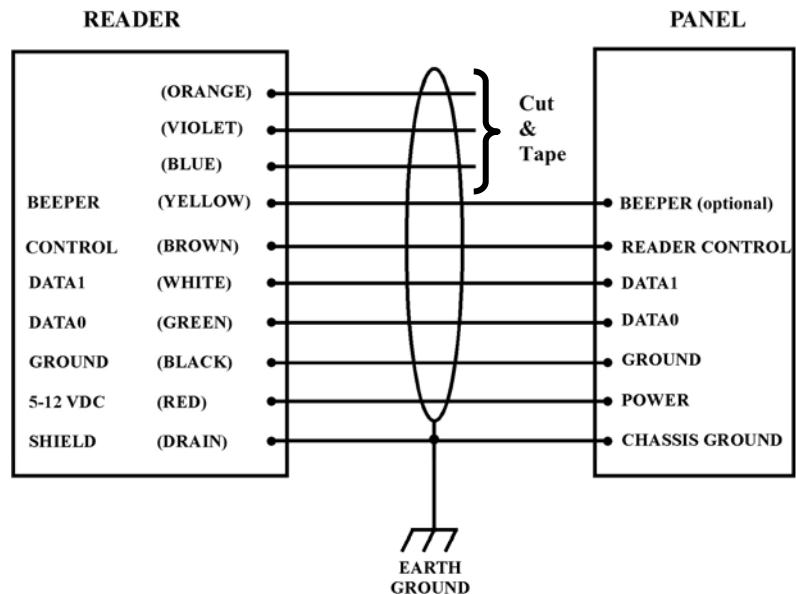

FIGURE 2. Wiring Diagram (Wiegand)